

ION SENSE

Product Guide





About ION SENSE

What we do

ION SENSE is a leading UK manufacturer of innovative sensing solutions. Our patented, humidity-resistant PID sensor technology is trusted by major global gas detection manufacturers for delivering fast, reliable, and accurate detection of volatile organic compounds (VOCs). Complementing our core offering, we also supply particulate matter (PM) sensors and integration boards designed to seamlessly bridge your gas sensor with your system.

Our commitment to you

We are committed to developing and manufacturing the best performing sensors to give you the most accurate and reliable measurements. This is backed by an unrivalled level of customer service and support. By bringing critical component manufacturing under our roof, we offer the best quality in the market whilst remaining price competitive.

Our sensors deliver accuracy, reliability and confidence, designed to **protect lives and preserve the environment.**

OEM Gas Sensors

Volatile Organic Compounds (VOCs)

Why use a VOC sensor?

VOCs are a wide range of naturally and synthetically occurring chemicals which are found almost everywhere. They are described as volatile because they evaporate at temperatures found on Earth, releasing molecules into the atmosphere. VOCs are extremely useful for mankind, they form the building blocks of many synthetic materials (plastics, rubbers, adhesives, paints etc.), used to create pharmaceuticals and are a great fuel for transport and heating. Whilst many VOCs have no adverse effects on health and the environment, some are harmful. Short term exposure health effects include eye, nose and throat irritation. Long-term exposure to very low concentrations which you may not be aware of, may damage the liver, kidneys, central nervous system and cause cancers. Therefore, accurate sensing of VOCs is critical for protecting people, the environment and optimising industrial processes.

Why use photoionisation detection (PID)?

VOCs can be measured in air using a variety of principles; however, some are cross-sensitive to common atmospheric gases including CO₂, CO, SO_x, NO_x and water vapour at ppb levels. PID is not sensitive to these and is recognised as the most accurate method for VOC detection. The key advantage of the ION SENSE PID sensor is its world leading humidity resistance and long-term stability. In addition, it offers the best temperature stability on the market.



Principle of PID

Photoionisation Detection (PID)

Photoionisation is produced by the absorption of a high energy photon by a molecule. If the energy of the photon is greater than the ionisation energy of the molecule it will be ionised.

Ions are detected at a pair of electrodes where changing current is proportional to concentration.

The figure below shows how an ION SENSE PID sensor works. A miniature UV lamp generates high energy photons, which pass through the lamp window into the ionisation/detection chamber. Sample gas diffuses through a membrane on the opposite side.

The inset on the lower right shows what happens on a molecular level. When a photon with enough energy strikes a molecule M, an electron (e-) is ejected. The M+ ion travels to the cathode and the electron (e-) travels to the anode, resulting in a current. This current is proportional to the gas concentration. The electrical current can be displayed as a ppm or ppb concentration. Not all molecules can be ionized. The major components of air, such as nitrogen, oxygen, carbon dioxide, argon, etc., do not cause a response, but most VOCs do give a response.

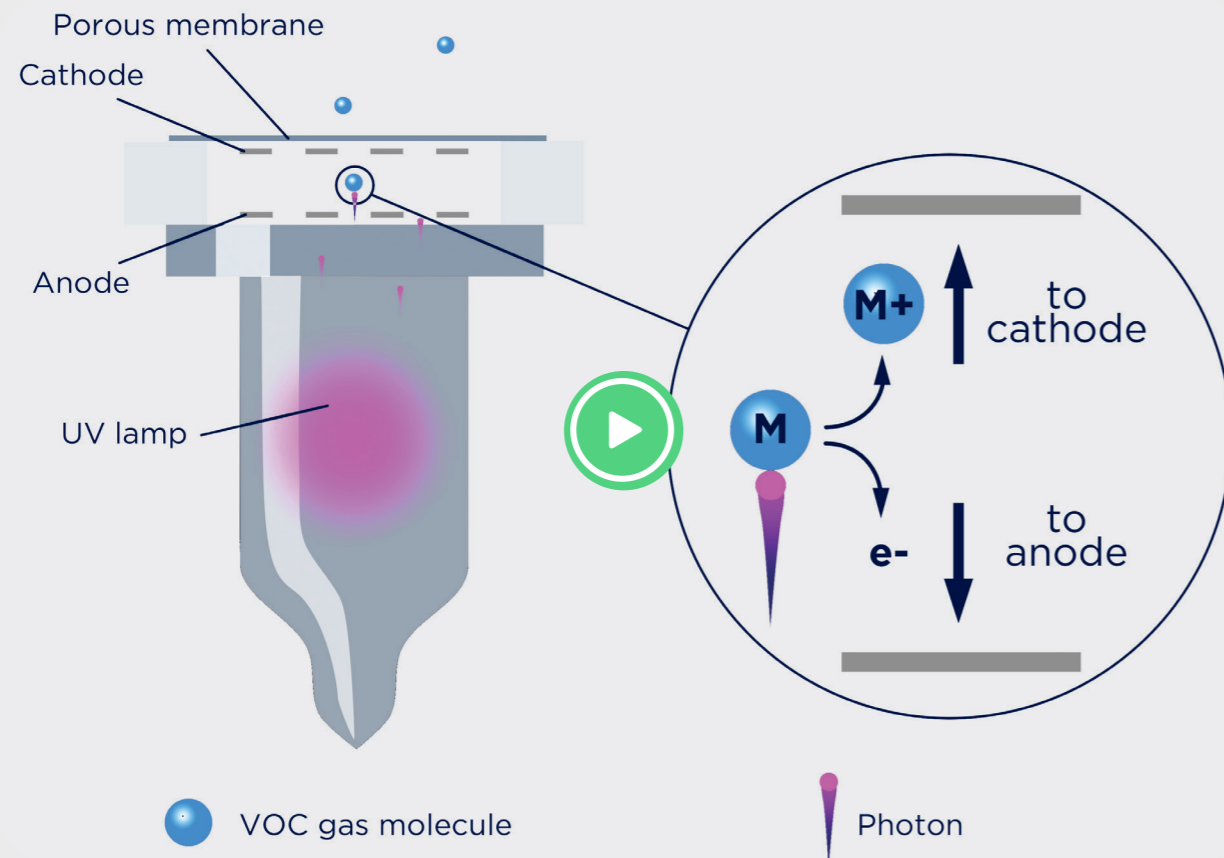

VOC gas molecule

Photon

What PID to Choose

10.0 eV, 10.6 eV or 11.7 eV?

We offer a range of PID sensors to offer the best solution for your application. The choice of PID begins with the gas you want to detect.

For successful detection of VOCs by PID the following guidelines are useful to follow:

- Less than 10 carbon atoms
- Have boiling point of less than 250 °C
- Have a vapour pressure greater than 4.0×10^{-5} mBar

If your target gas meets these criteria the next step is decide what energy (eV) sensor you require. ION SENSE has three energy sensors: 11.7, 10.6 and 10.0 eV. The 11.7 sensor detects the most chemicals, 10.0 the least. If you are interested in only detecting VOCs with a lower ionisation energy a lower energy sensor will provide a level of selectivity. A common use of lower energy sensors is detecting aromatics, including BTEX. Aromatics have ionisation energies less than 10.0 eV and are commonly present with long chain hydrocarbons with higher ionisation energies.

12.3	IE	Methane
11.32	IE	Dichloromethane
10.87	IE	Formaldehyde
10.85	IE	Methanol
10.54	IE	Methyl Bromide
10.43	IE	Hydrogen Sulphide
10.43	IE	Ethanol
10.18	IE	Ammonia
10.17	IE	Isopropanol
10.13	IE	Hexane
9.25	IE	Benzene
9.07	IE	Butadiene
8.56	IE	Xylene

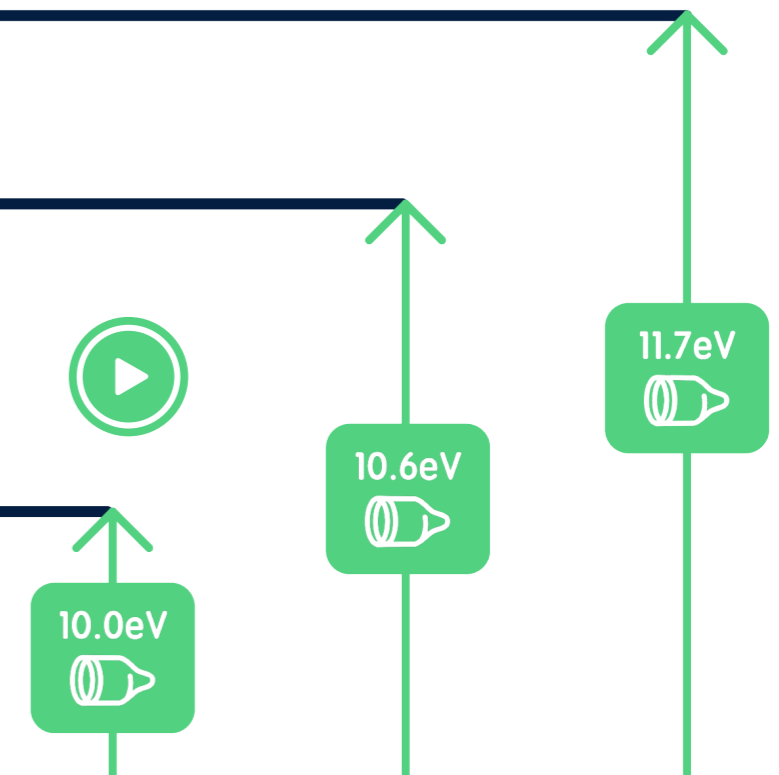

The next step of sensor choice depends on the concentration you want to measure, this is broadly divided into ppb or ppm measurement.

MiniPID 2

OEM gas sensor with state of the art technology

ION SENSE has an OEM gas sensor portfolio that offers market-leading photoionisation technology, capable of detecting extremely low-levels of volatile organic compound (VOC) gases, to be used alone or for successful integration into instruments.



Humidity Resistant



Anti-Contamination Design



Superior Stability



ION SENSE PID

A new era in VOC detection

ION SENSE PID sets a new industry benchmark in photoionisation detection, delivering unmatched performance, accuracy, and reliability. Designed with cutting-edge technology, this next-generation sensor redefines VOC detection, offering superior sensitivity and long-term stability in even the most challenging environments.

We are actively seeking forward-thinking industry partners to trial ION SENSE PID products. If you're interested please contact us at sensors@ionsense.com to arrange an evaluation.



6x Humidity Resistance



>15,000 Hour Lamp & Filter Life



50% Faster Response Time



PID Sensor Technical Specification



OEM gas sensors with state of the art sensing technology

For comprehensive specifications on power, signal, environmental performance, and product lifetime, please refer to the individual product datasheets available at ionsense.com.

Sensor	MiniPID 2 PPM WR	MiniPID 2 PPM	MiniPID 2 PPB WR	MiniPID 2 PPB	MiniPID 2 PPB XF
Electrode Stack Colour	Blue	Blue	White	White	White
Minimum Detection Limit	500 ppb	100 ppb	20 ppb	1 ppb	1 ppb
Range	>10,000 ppm	>4,000 ppm	>200 ppm	>40 ppm	>40 ppm
Response Time T90 (S)	<3	<3	<8	<8	<12
Sensitivity	>0.4 mV / ppm @ 100 ppm	>0.65 mV / ppm @ 100 ppm	>5 mV / ppm	>30 mV / ppm	>30 mV / ppm
Lamp Energy	10.6 eV	10.6 eV	10.6 eV	10.6 eV	10.6 eV

Sensor	MiniPID 2 HS	MiniPID 2 10.0eV	MiniPID 2 11.7eV	ION SENSE PID*
Electrode Stack Colour	Red	White + gold spot	White	Stainless steel
Minimum Detection Limit	0.5 ppb	5 ppb	100 ppb	100 ppb
Range	0-3 ppm	>100 ppm	>100 ppm	>100 ppm
Response Time T90 (S)	<12	<8	<8	<8
Sensitivity	>600 mV / ppm	>15m V / ppm	>1 mV / ppm	>1 mV / ppm
Lamp Energy	10.6 eV	10.0 eV	11.7 eV	10.6 eV

CONTACT US TO TRIAL*

ION SENSE also offers detailed resources on the detection of up to 950 Volatile Organic Compounds (VOCs), which can be accessed here: [TA-02](#)

*If you're interested in trialling ION SENSE PID please contact us at sensors@ionsense.com to arrange an evaluation.

PID Sensor Technical Details

MiniPID sensor dimensions

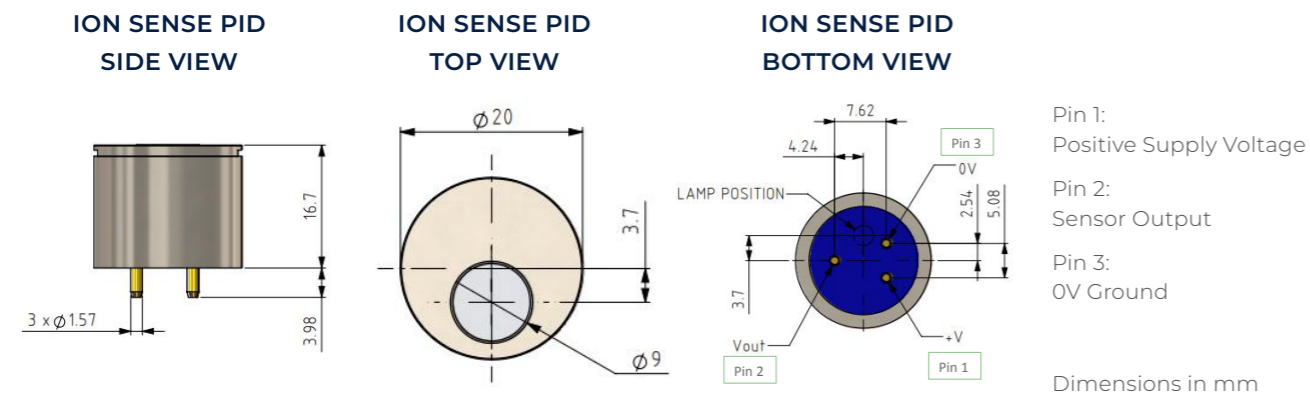
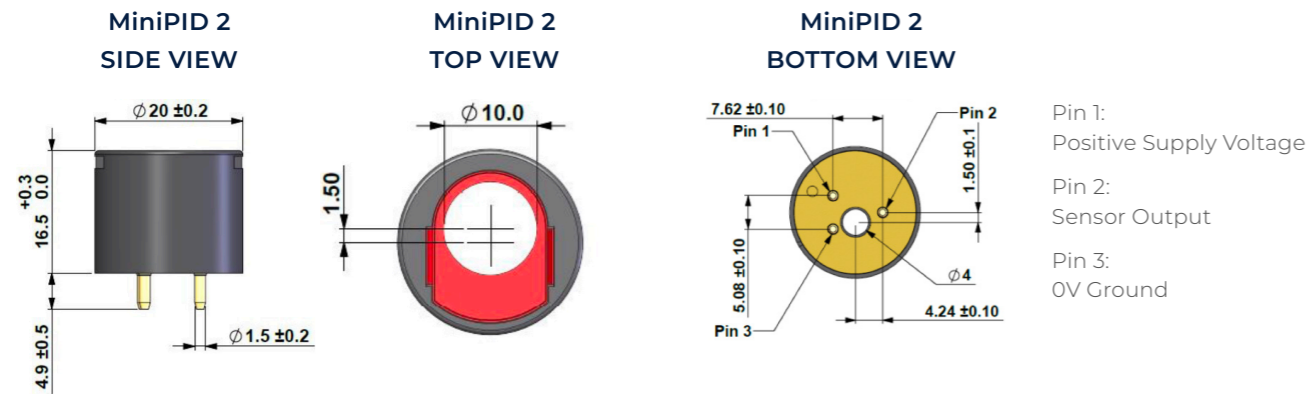

NextPM

The most advanced particle measurement solution on the market

NextPM has been designed to meet the very highest performance standards in all applications. Featuring advanced technical specifications that enable ultra-precise measurements to be obtained, even in extreme climatic conditions.



- Anti-Contamination Design
- Humidity Resistant
- Direct Measurement PM 1, 2.5, and 10

NextPM Technical Specification

CE RoHS

Real-time PM1, PM2.5, and PM10 measurements

Performance

Particle Size Detection Range	0.3–10 (µm diameter)
Detection Efficiency with 0.3 µm Diameter Particles	>50 (%)
Concentration Detection Range / PM10 - PM2,5 - PM1	0–1000 µg/m ³ (Arizona dust A1 equivalent)
Temperature Influence	
0 °C to 30 °C	0 % / °C
-20 °C to 0 °C	<+1.0 % / °C
30 °C to 70 °C	<-0.8 % / °C

Electronics

Power Supply	5.0 (VDC)
Power Consumption in Operation	<80 (mA) 300 (Maximum)
Power Consumption in Sleep Mode	<20 (mA)

General

Technology	Optical
Airflow	2.5 (L/mn)
Size	Annex 1 (mm/Inches)
Lifetime	>10,000 hours



Next Generation Integration Boards

ION CONNECT, ION TRANSMIT and ION PROGRAM

For rapid PID sensor evaluation and integration

Our integration boards allow rapid evaluation and provide seamless installation options, allowing for adaptation across diverse applications, from compact air quality monitors to comprehensive industrial systems.

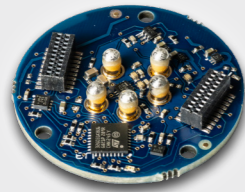

ION CONNECT

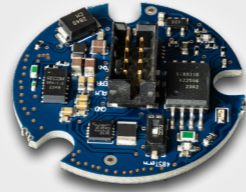

ION TRANSMIT

The ION TRANSMIT board ensures effective long-range communication for remote monitoring, while the ION CONNECT board facilitates easy data interpretation by converting analogue signals into digital outputs. Advanced features such as MODBUS compatibility streamline system control, thereby enhancing operational efficiency across diverse applications.

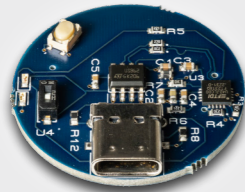

ION PROGRAM



ION GAS HOOD

The ION PROGRAM board provides a simple interface between the ION CONNECT module and a PC through a USB-C to USB-A connection. This allows seamless use of the intuitive ION PC software, developed to support the efficient evaluation and integration of both the trusted MiniPID 2 sensor range and the latest ION SENSE PID sensors. The ION PROGRAM board also serves as a bridge for firmware updates when required. The software can be downloaded separately at ionsense.com.

The ION GAS HOOD attaches to the Integration Boards, and is designed to deliver impressed flow to ION SENSE PID and MiniPID 2 sensors.

Integration Boards Technical Specification

ION CONNECT

Dimensions	32 mm diameter
Weight	4 g
Nominal Voltage	3.3–5.5 VDC
Operating Humidity	0–99 % RH (non-condensing)
Operating Temperature	-20–+60 °C
Communication Protocol	UART & I ² C

ION TRANSMIT

Dimensions	32 mm diameter
Weight	4 g
Nominal Voltage	12–24 VDC
Typical Power	At 24 V 25 mA unloaded, 31 mA with sensor / At 12 V 31 mA unloaded, 44 mA with sensor
Operating Humidity	0–99 % RH (non-condensing)
Operating Temperature	-20–+60 °C
Communication Protocol	MODBUS RTU & 4–20 mA





Applications



Indoor Air Quality

Accurate monitoring of VOCs and particulates is essential to maintain healthy indoor environments. ION SENSE's PID and PM sensors provide fast, reliable detection with excellent sensitivity and stability. Their low power consumption and improved lamp life ensures consistent performance in offices, schools, and residential buildings for long-term air quality management.



Urban Air Quality

ION SENSE's sensors deliver outstanding repeatability, extended range, and robust EMI performance, making them ideal for roadside monitoring stations or portable devices. Their patented humidity resistance and stability support continuous deployment, giving communities the accurate data needed for regulatory compliance and protection.



Industrial Health & Safety

Workers in manufacturing, chemical, and refining industries face risks from toxic gases and particulates. ION SENSE's sensors provide rapid response times and superior repeatability, detecting harmful compounds before exposure becomes dangerous. Their durability, low cost of ownership, and reliable performance in harsh conditions make them essential for safety compliance.



HVAC & Building Control

Modern building systems require precise air monitoring to optimise comfort, efficiency, and safety. ION SENSE's sensors offer fast response and excellent linearity, ensuring accurate integration into HVAC systems. Their compact design and long filter life reduce maintenance needs, supporting energy efficiency and healthier indoor environments in smart buildings.

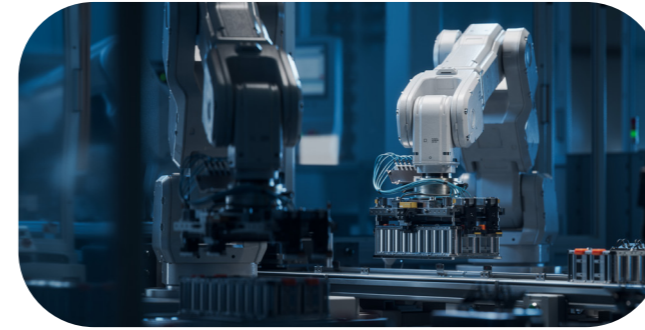

Lithium-ion Battery Lifecycle

Comprehensive monitoring throughout the lithium-ion battery lifecycle ensures safe manufacturing, consistent quality, and safe use. During production, detecting NMP exposure is critical for worker safety, and PID sensors provide sensitive, real-time VOC monitoring. After manufacturing, they detect electrolyte carbonates for quality assurance. In use, they offer early warning of thermal runaway by sensing carbonate emissions. Their high sensitivity, stability, and low power consumption make them ideal for lifecycle-wide integration.

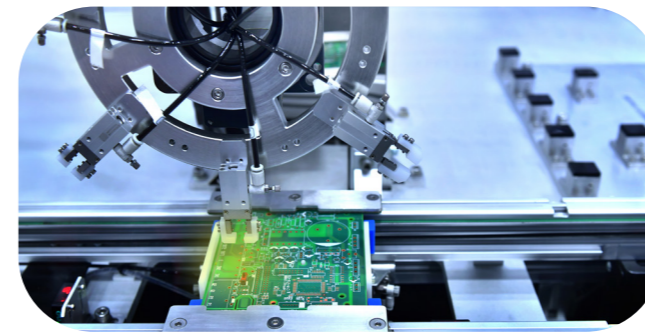

Semiconductor

Semiconductor manufacturing requires strict VOC control to protect processes and personnel. ION SENSE sensors provide sensitive, stable monitoring in cleanrooms and production areas, supporting contamination control and worker safety. Their fast response and durability also enable effective fenceline monitoring, helping prevent emissions, ensure compliance, and protect yield, health, and surrounding communities.



Emergency Response & HAZMAT

First responders need immediate, accurate detection of hazardous gases and particulates during incidents. ION SENSE's sensors deliver rapid response, wide detection ranges, and robust performance in challenging conditions. Lightweight, low-power, and highly repeatable, they are trusted in portable devices that help protect emergency teams and the public in critical situations.



Fugitive Emissions

Key to monitoring fugitive emissions of VOCs from pipelines, storage tanks, and process equipment, our highly sensitive, fast-responding PID sensors detect VOCs at very low concentrations. This enables early leak detection and ensures compliance with regulatory standards. Suitable for routine surveys, fenceline monitoring, and fixed installations, PID technology is widely adopted across petrochemical, refining, chemical manufacturing, and waste management industries.



Applications



Environmental

VOCs from industrial emissions, traffic, and waste processing contribute to air pollution and environmental harm. ION SENSE's sensors deliver high sensitivity and fast response times, enabling accurate detection of low-level VOCs in changing outdoor conditions. Their superior stability and humidity resistance ensure reliable long-term environmental monitoring.



Construction

Construction activities release VOCs from fuels, solvents, coatings, and building materials, posing risks to workers and nearby communities. ION SENSE's sensors provide rapid detection and strong resistance to dust and contamination, making them ideal for dynamic site conditions. Their durability and fast stabilisation support real-time safety monitoring.



Compressed Air & Breathing Apparatus

Compressed air systems can become contaminated with oil vapours and other VOCs from compressors and surrounding environments. ION SENSE's sensors provide reliable detection of these contaminants, ensuring air quality meets safety standards. Their long lamp life and superior stability enable dependable, continuous monitoring.



Fruit Storage, Transport & Ripening

Ethylene regulates fruit ripening, so accurate monitoring is vital for storage and transport. ION SENSE PID sensors precisely detect ethylene and other VOCs, helping optimise ripening and reduce spoilage. Their high sensitivity and stability support low-level detection over long periods, improving quality and supply chain efficiency.



Hydrogen Economy

Hydrogen storage and transport increasingly use ammonia as a carrier, introducing risks from leaks and residual impurities. ION SENSE PID sensors precisely detect ammonia and volatile by-products for safe storage and handling. After cracking to hydrogen, they identify trace impurities in the gas stream, supporting efficiency and system integrity. Their stability and low power consumption make them well-suited for continuous monitoring across hydrogen infrastructure.



Research & Fertility Laboratories

Laboratory environments often use solvents and chemicals that emit VOCs during handling and analysis. ION SENSE's sensors offer fast response times and excellent repeatability, ensuring accurate detection of trace compounds. Their anti-contamination design and long filter life support consistent performance in controlled settings.



Leak Detection & Repair (LDAR)

Industrial equipment and pipelines can leak VOCs such as hydrocarbons, posing environmental and safety risks. ION SENSE's sensors deliver rapid response and high sensitivity, enabling quick identification of leaks. Their portability, durability, and resistance to contamination make them ideal for routine LDAR programs.

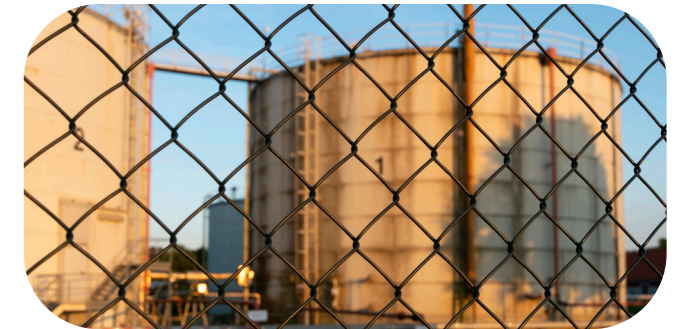

Fenceline

Industrial sites can emit VOCs that impact surrounding communities, requiring continuous perimeter monitoring. ION SENSE's PID sensors offer high sensitivity and stability for detecting low-level emissions over large areas. Their durability and resistance to environmental factors support reliable, long-term fenceline monitoring.



Sensor Selector Guide

What is your application?	MiniPID 2 PPM WR	MiniPID 2 PPM	MiniPID 2 PPB WR	MiniPID 2 PPB	MiniPID 2 PPB XF
Indoor Air Quality	-	-	✓	✓	✓
Urban Air Quality	-	-	✓	✓	✓
Industrial Health & Safety	✓	✓	✓	✓	-
HVAC & Building Control	-	-	✓	✓	✓
Lithium-ion Battery Lifecycle	-	-	-	✓	✓
Emergency Response & HAZMAT	-	✓	-	✓	-
Semiconductor	-	✓	-	✓	-
Fugitive Emissions	-	-	-	✓	✓
Environmental	-	-	-	✓	✓
Construction	-	-	-	✓	-
Hydrogen Economy	-	-	-	-	-
Laboratory	-	-	-	-	✓
Breathing Apparatus / Compressed Air	-	-	-	-	-
Fruit Storage, Transport & Ripening	-	-	-	✓	✓
Leak Detection & Repair (LDAR)	✓	-	✓	-	-
Fertility Labs	-	-	-	-	-
Wing Tank Entry	-	-	-	✓	-
Fenceline	-	-	-	-	✓

Sensor Selector Guide

What is your application?	MiniPID 2 HS	MiniPID 2 10.0eV	MiniPID 2 11.7eV	ION SENSE PID	NextPM
Indoor Air Quality	✓	✓	✓	✓	✓
Urban Air Quality	✓	✓	-	✓	✓
Industrial Health & Safety	✓	✓	✓	✓	✓
HVAC & Building Control	✓	✓	-	✓	✓
Lithium-ion Battery Lifecycle	-	-	-	✓	-
Emergency Response & HAZMAT	✓	-	-	✓	-
Semiconductor	✓	-	-	✓	✓
Fugitive Emissions	✓	✓	-	✓	✓
Environmental	-	-	-	✓	✓
Construction	✓	✓	-	✓	✓
Hydrogen Economy	✓	-	-	✓	-
Laboratory	✓	-	-	✓	✓
Breathing Apparatus / Compressed Air	✓	-	-	✓	-
Fruit Storage, Transport & Ripening	✓	-	✓	✓	-
Leak Detection & Repair (LDAR)	✓	-	-	-	-
Fertility Labs	✓	-	-	✓	✓
Wing Tank Entry	-	-	-	✓	-
Fenceline	✓	-	-	✓	✓

Spares and Repairs

Additional accessories and replacement parts for your MiniPID sensors



Sensor stack removal tool

The MiniPID 2 sensor stack removal tool allows safe, easy removal of the stack from the MiniPID 2 sensor.

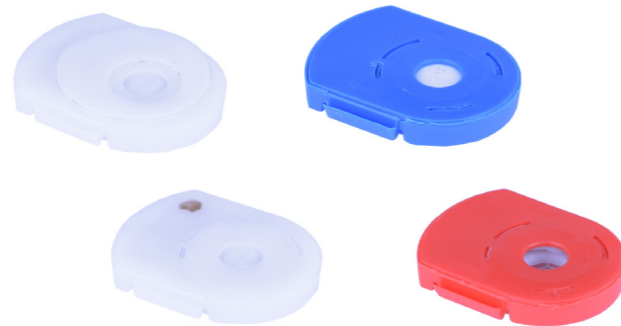

Electrode stacks

We offer 4 different electrode stacks providing different sensitivities and ranges.



Lamps

We offer lamps with different energies and voltages.



PID lamp cleaning kit

Used to clean the lamp within the ION SENSE PID sensor to remove dirt, grease and grime from the lamp window ensuring optimal performance. Also compatible with MiniPID 2.

For the full list of spare parts please contact sensors@ionsense.com



Contact ION SENSE

Thank you for exploring the ION SENSE product range

We're dedicated to advancing sensor technology that delivers accuracy, reliability, and confidence, and our team is ready to support you every step of the way. Request an **Evaluation Kit** today and experience the performance of our sensors first-hand.

Our head office and manufacturing facility is located just outside of Cambridge in the UK: ION SENSE, The Hive, Butts Lane, Fowlmere, Cambridgeshire, SG8 7SL, UK



[+44 \(0\)1763 208503](tel:+441763208503)



sensors@ionsense.com



ionsense.com



ION SENSE Global Offices

ION SENSE - UK

The Hive, Butts Lane,
Fowlmere, Cambridgeshire,
SG8 7SL, UK

[+44 \(0\)1763 208503](tel:+44201763208503)

sensors@ionsense.com

ionsense.com

Visit us on [LinkedIn](#)

ION SENSE - France

41 rue des Etoiles
83240 Cavalaire / Mer
France

[+33 613 505 535](tel:+33613505535)

ionscience.com/fr

ION SENSE - Germany

Laubach 30,
Mettmann, Neandertal,
D-40822, Germany

[+49 2104 14480](tel:+49210414480)

ism-d.de

ION SENSE - India

#1-90/B/C/3/1,G-10,
Charmy, Vittal Rao Nagar,
Image Hospital Lane Madhapur,
Hyderabad – 500 081,
Telangana State, India

[+91 -40-4853 6129](tel:+914048536129)

ionscience.com/in

ION SENSE - Italy

Vie delle Querce 1/g 40011
Anzola dell'Emilia (Bologna)
Italy

[+39 051 0561850](tel:+390510561850)

ionscience.com/it

ION SENSE - America

4153 Bluebonnet Drive
Stafford, Texas,
77477, USA

[+1 877 864 7710](tel:+18778647710)

ionscience.com/usa

ION SENSE - China

1101, Bldg B,
Far East International Plaza
No` 317, Xianxia Road,
Shanghai, China

[+86 21 52545988](tel:+862152545988)

ionscience.cn